

## OPTImill®\* MH 50G / MH 50V

**Universal precision drilling/milling machines with manual gearbox and electrical Z axis adjustment.  
MH 50V with electronically controlled drive.**

Control unit with dirt- and water-resistant membrane keyboard

### Facts that impress in terms of quality, performance and price

- ▶ Control panel with user-friendly dirt and water resistant foil keyboard
- ▶ Easily readable digital display
- ▶ Easily readable spindle sleeve display in milling head
- ▶ Drilling depth stop
- ▶ Right-handed/left-handed rotation
- ▶ Thread tapping mode
- ▶ Rotary pushbutton on control panel for adjusting the drilling depth, optionally in mm or inches, with zero point
- ▶ Excellent concentricity thanks to tapered roller bearings, better than 0.015 mm measured in the spindle sleeve
- ▶ Gear head pivots through  $\pm 30^\circ$
- ▶ Electrical milling head height adjustment
- ▶ Manual fine feed
- ▶ Adjustable cleats
- ▶ Height-adjustable protective screen with microswitch for best possible user protection against chips and parts being flung out
- ▶ Heavy, sturdy and solid columns made of premium cast material with ground and shaven dovetail guide for excellent stability and precision
- ▶ Z axis with slatted, stainless steel protective cover
- ▶ Solid and generously dimensioned cross table with precision surface finish and T-slots
- ▶ Optional, solid, heavy steel chassis ensures stability

### MH 50G:

- ▶ Two-stage industrial quality electric motor

### MH 50V:

- ▶ 6 speeds, electronically controlled

### Energy chain



> cable guidance easy on material

### Mechanical Quick change clamping system



- > The milling head is equipped with spring collet for pull stud BT40x45°
- > To change, simply release the mechanical lock on the quick-clamping system and push the spindle sleeve lever upwards



## Technical specifications, accessories and dimensions

Model	MH 50G	MH 50V***
Article no.	3338180	3338185
<b>Technical data</b>		
Electrical connection	400 V / 3 Ph ~ 50 Hz	
Motor output	1.5 / 2.2 kW	2.2 kW
<b>Drilling/milling output</b>		
Drilling performance in steel (S235JR)	Ø 38 mm	
Continuous drilling performance in steel (S235JR)	Ø 32 mm	
Max. sensor head size	Ø 80 mm	
Max. shaft milling cutter size	Ø 32 mm	
<b>Spindle</b>		
Spindle sleeve stroke	115 mm	
Spindle seat	BT 40	
Spindle sleeve diameter	80 mm	
Throat	260 mm	
<b>Drilling/milling head</b>		
Spindle speeds	225 - 3 260 rpm	50 - 3 260 rpm
Speeds	2 x 6 speeds	6 speeds electr. controlled
Pivot range	± 30°	
<b>Cross table</b>		
Length x width	850 mm x 240 mm	
T-Slot size / no / distance	18 mm / 3 / 80 mm	
Max. load bearing capacity	175 kg	
Clearance spindle to cross table	max. 545 mm	
<b>Travel</b>		
X axis manual	520 mm	
Y axis manual	260 mm	
Z axis	manual 465 mm / automatic 385 mm	
<b>Dimensions</b>		
Length x width x height max.	1 210 x 1 020 x 1 645 mm	
Weight	525 kg	

Accessories	Article no.
Milling head holder Ø 27 mm	3353336
Quick clamping drill chuck 1 - 13 mm	3536303
Weldon holder Ø 6 mm	3353340
Weldon holder Ø 8 mm	3353341
Weldon holder Ø 10 mm	3353342
Weldon holder Ø 12 mm	3353343
Weldon holder Ø 16 mm	3353344
Weldon holder Ø 20 mm	3353345
BT 40 - MT 3 adapter	3353335
Spring collet holder ER 32	3353334
Spring collet holder spanner ER 32	3353307
Collet kit ER 32	3441122
Height-adjuster	3536290
Assembly and tool adjustment gauge	3536193
Taper squeegee	3353331
Pull stud 40 x 45° M16	3353332
Pull stud DIN2080 M16	3536179
Universal table feed V99	3352022
Assembly kit V99 - X axis	3352036
Assortment of clamping tools size 16, 58-parts	3352019
Steel chassis (information on page 135)	3353015
Levelling platen SE 55 (4 pcs. required)	3352981
Vibration damping machine base SE1 (4 pcs. required)	3381012
› More accessories for milling machines from page 126	

\*\* Important information on transport surcharge and „Operation of machines with frequency converters“ on page 253  
 \*\*\*The milling machine complies with the DIN EN 55011 standard: class C2.

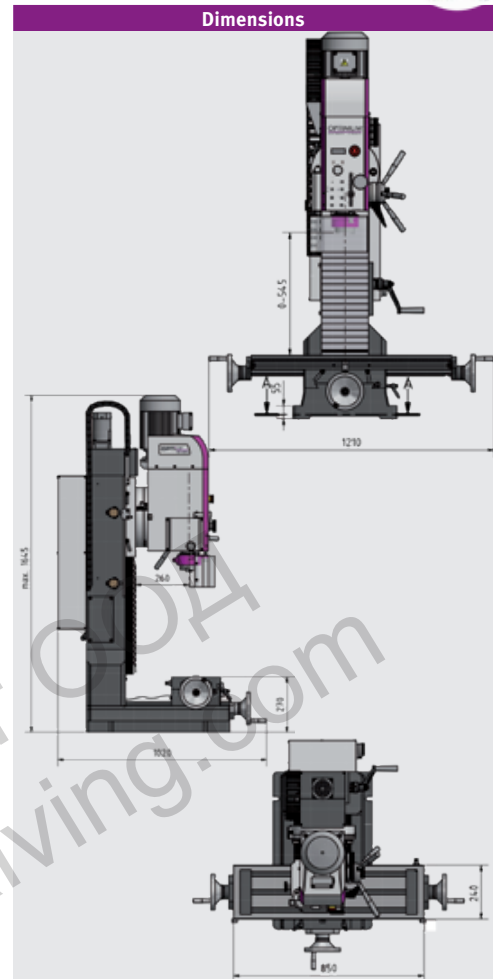

### Scope of supply

› Operating tool

### Accessories

**Starter set BT 40** Article no. 3353284

- › Milling head holder Ø 27 mm
- › Quick-action drill chuck 1 - 13 mm
- › 2 pcs. Weldon Ø 6 mm and 20 mm
- › 1 pc. each Weldon Ø 8 / 10 / 12 / 16mm
- › BT 40 - MT 3 adapter
- › 3 pcs. spring collet holder ER 32
- › Spring collet key ER 32
- › 18-part Collet kit ER 32
- › Height-adjuster
- › Assembly and tool adjustment gauge
- › 14 pcs. pull studs
- › Taper squeegee

### Machine vices

Machine vices	Article no.
FMS 125	3354125
FMSN 125	3354120
VMQ 100	3354181
MV3-75	3354175
DAS 100	3355500
ZAS 50	3354170

› Information about vices from page 120